

Design of Separation Schemes for Fractional Crystallization of Metathetical Salts

Luis A. Cisternas, Mauricio A. Torres, and María J. Godoy

Dept. de Ingeniería Química, Universidad de Antofagasta, Antofagasta, Casilla 170, Chile

Ross E. Swaney

Dept. of Chemical Engineering, University of Wisconsin-Madison, Madison, WI 53706

The synthesis method of fractional crystallization processes for the separation of salts belonging to reciprocal salt pairs is presented based on a flow network model constructed between thermodynamic states. The state nodes represented in the model include feeds, products, intermediate products, and solid-liquid equilibrium states. Flows between the states are represented by arcs within the flow model. A systematic procedure is given for identification of the solid-liquid equilibrium states that could potentially serve as operating points. This identification is essential to the construction of the flow network and reduces the problem to a simple mathematical form. The advantages of the method lie in its capability to consider general process flow pattern, handle systems forming double salt, deal with several temperatures as potential operation conditions, and handle several feeds and products. Examples are given to illustrate the procedure.

Introduction

Crystallization or precipitation of salts from aqueous solutions is a widely used method in industrial processing. This method is used to prepare various salts, such as sodium sulfate and potassium nitrate. Numerous articles have been published over the past ten years concerning the synthesis of separation processes to obtain salts from brines and mixtures of salts. These studies can be classified into two categories: those that use a phase diagram to identify the types of processes that may be applied to specific types of liquid-solid equilibrium behavior (Ng, 1991; Cisternas and Rudd, 1993; Dye and Ng, 1995; Berry and Ng, 1996), and those that use a network flow model between *a priori* determined thermodynamic states that allow selection of an optimal structure (Cisternas and Swaney, 1998; Cisternas, 1999; Cisternas et al., 2001). The majority of these studies, however, do not address systems containing metathetical salts. When two salts have no ions in common, a double decomposition can occur in which a pair of salts is reconstituted into another pair. This phenomenon is known as reciprocal salt pairing, or a metathetical salt system. This type of system is of interest for the pro-

duction of various chemical compounds, for example, the production of potassium nitrate beginning with sodium nitrate and potassium chloride. Purdon and Slater's (1946) book describes precisely how to present such phase equilibrium data in a diagram. These authors also explained how to present evaporation paths by means of phase diagrams. Fitch (1970) discussed how the phase diagram could be used to represent processes for fractional crystallization, including the treatment of reciprocal salt pairs. However, he did not address the problem of synthesizing the process flowsheet. Berry and Ng (1996) gave a method for the separation of salts in the pure, solid state for reciprocal salt-pair systems. They identified three classes of separations that could be used to separate simple salts from a solution. These separation classes could be used as guidelines for the conceptual design of separation processes for these systems. However, this procedure is limited, as it is commonly found that metathetical salt systems can have complex behaviors that do not compare with the examples studied by Berry and Ng (1996), or specific problem conditions may apply, such as the existence of more than one feed. Also, certain flow-pattern alternatives, such as stream splitting or mixing, may be difficult to envision within the phase diagram. In another study, Thomsen et al. (1998)

Correspondence concerning this article should be addressed to L. A. Cisternas.

simulated and optimized fractional crystallization processes, including reciprocal salt pairs. The analysis of alternatives that can be obtained by simulation is limited, however, because a very large number of processing possibilities exist.

The present study presents a method for the design of separation schemes based on fractional crystallization for systems formed of reciprocal salt pairs. The method is based on a network model with flows between thermodynamic states. Using the phase diagram, a method is developed for identification of a set of solid-liquid equilibrium points that are believed to include the best prospects for operating points. Then, based on these points, only the feasible physical interconnections are identified, in order to reduce the number of arcs in the flow network. A mathematical model is developed based on the network flow model to find the optimal flow pattern for the separation of the reciprocal salt pairs.

Development of Methodology

An example consisting of the production of potassium nitrate and sodium chloride from potassium chloride and sodium nitrate will be used to explain the methodology. Equilibrium data from this system, used graphically here, are available in Linke and Seidel (1965).

Description of the problem

A reciprocal salt pair is formed by dissolving two salts that do not have common ions in a solvent, which for most practical purposes is water. Through a metathesis reaction, a total of four simple salts may precipitate from this solution. For example, in the reaction between NaNO_3 and KCl , KNO_3 and NaCl (the conjugated pair of the other two salts) can be produced by the following reaction

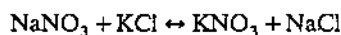

Furthermore, the ions can interact between themselves and the solvent to produce double salts and hydrates. The behavioral characteristics of the system equilibrium are generally represented by a phase diagram.

Figure 1 is a phase diagram representing an aqueous system formed by monovalent salts formed by the Na^+ , K^+ , Cl^- , NO_3^- , and H_2O system at 298 K. The coordinates of one point in the diagram are given by the ratio of the concentration of K^+ to the total cation concentration, the ratio of the concentration of NO_3^- to the total concentration of anions, and by the moles of solvent per equivalent of salts. The points A, C, E, and G are the saturated solutions of pure salts dissolved in the solvent. The double saturation points (B, H, F, D) represent ternary solutions saturated with two salts. Points I and J represent triple saturation points of the quaternary system. Regions formed by the A-H-I-J-B, C-B-J-D, E-D-J-I-F, and G-H-I-F borders represent saturation surfaces of the KNO_3 , KCl , NaCl , and NaNO_3 salts, respectively. The F-I, H-I, D-J, B-J, and J-I borders represent conditions under which the solution is saturated by two salts. Not all the combinations are possible, and thus no conditions exist in the phase diagram of Figure 1 under which KCl and NaNO_3 can be cocrystallized.

These two salts are termed incompatible salts, while the NaCl - KNO_3 pair, which cocrystallize at border J-I, are

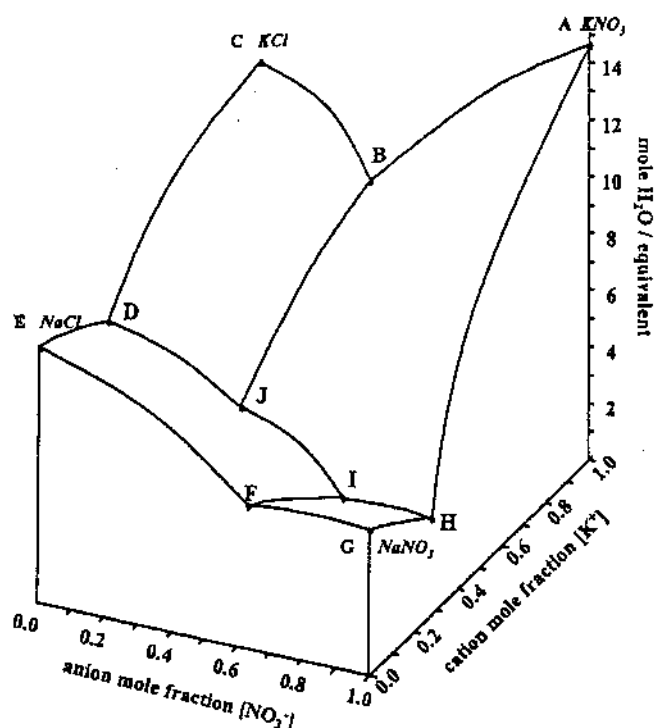

Figure 1. Phase diagram for the $\text{Na-K-NO}_3\text{-Cl-H}_2\text{O}$ system at 298 K.

termed compatible salts. The phase diagram as presented in Figure 1 is not the most amenable for representing separation processes. This is not only because the graphical representation is complicated, but also because more than one isotherm must be shown in order to design processes for separation by fractional crystallization. For this reason, it is more common to present this type of system using the Jänecke projection. Figure 2 is a Jänecke projection of the system given in Figure 1. The saturation points have been indicated by the same letters as used in Figure 1. In addition to the 298 K, case of Figure 1, the phase diagram at 373 K is also included.

It is possible to design various processing alternatives between these two temperatures. For example, assume that the production of KNO_3 (and thus NaCl) is desired beginning with KCl and NaNO_3 . One possible process is indicated in Figure 2 by points O, R, P, and Q. An equimolar mixture of KCl and NaNO_3 is mixed at point O, representing the process feed. This feed is mixed with saturated solution P, producing mixture Q at 373 K. The solvent quantity is adjusted in order to precipitate NaCl and generate solution R. This last solution is cooled and the solvent adjusted in order to crystallize KNO_3 and produce solution P, which is recycled to the process. An alternate process using the same point R is shown with points O, S, R, and T, where the feed is mixed with the solution at point R to produce point S, which, after adjustment of the solvent at 298 K, allows crystallization of KNO_3 to obtain solution T. Solution T is heated to 373 K, and its solvent is adjusted in order to obtain point R and NaCl . It is clear that more alternatives exist, such as splitting the feed flow O, mixing it with solutions P and R (Figure 3a), or using a mixture rich in KCl as feed (point O in Figure 3b), and, after reaching point R, adding the remaining quantity of

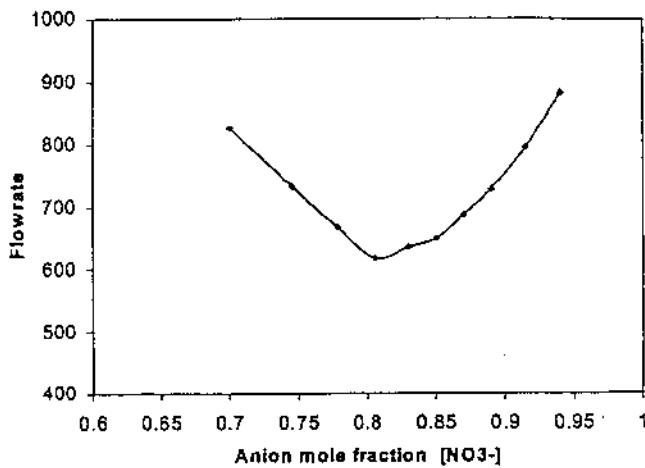

Figure 4. Variation in the molar recirculation flow per 100 mol of feed as a function of the location of point *R* in Figure 2.

point *R* across the *NM* and *LM* borders. Figure 4 shows how the recirculation flow varies as the composition of solution *R* changes. A minimum in the flow is observed when the composition corresponds to the triple saturation point *M*. This

behavior has been observed in other studies (Berry and Ng, 1996; Dudczek, 2001), and is related to the fact that maximum precipitation is achieved at these points. Thus, the initial selection of operating points should include the triple saturation points.

The system just discussed above is shown again in Figure 5, where the triple saturation points have been identified by the letters C_1 and C_2 for the system at 298 K, and H_1 and H_2 for the system at 373 K. Only these two temperatures have been considered, although it would be possible to include more temperatures in the analysis. Now consider Figure 5a, where H_1 is in equilibrium with KCl , $NaCl$, and KNO_3 , and therefore in principle could be used to produce any one of these salts. However, this requires operation points in the phase diagram that must be in the tie line that include the triple saturation point. Such lines, which are shown in Figure 5, connect together the compositions of two phases in equilibrium with each other. Because maximum precipitation is desired, such points must be double saturation points at the same time. Thus, C_3 could be used to produce KCl by means of the C_3H_1 trajectory, and C_4 could be used to produce $NaCl$ by means of the C_4H_1 trajectory. However, no double saturation point exists between H_1 and KNO_3 , and so it is impossible to produce KNO_3 at point H_1 . Thus, by tracing lines between the point that represents the triple saturation

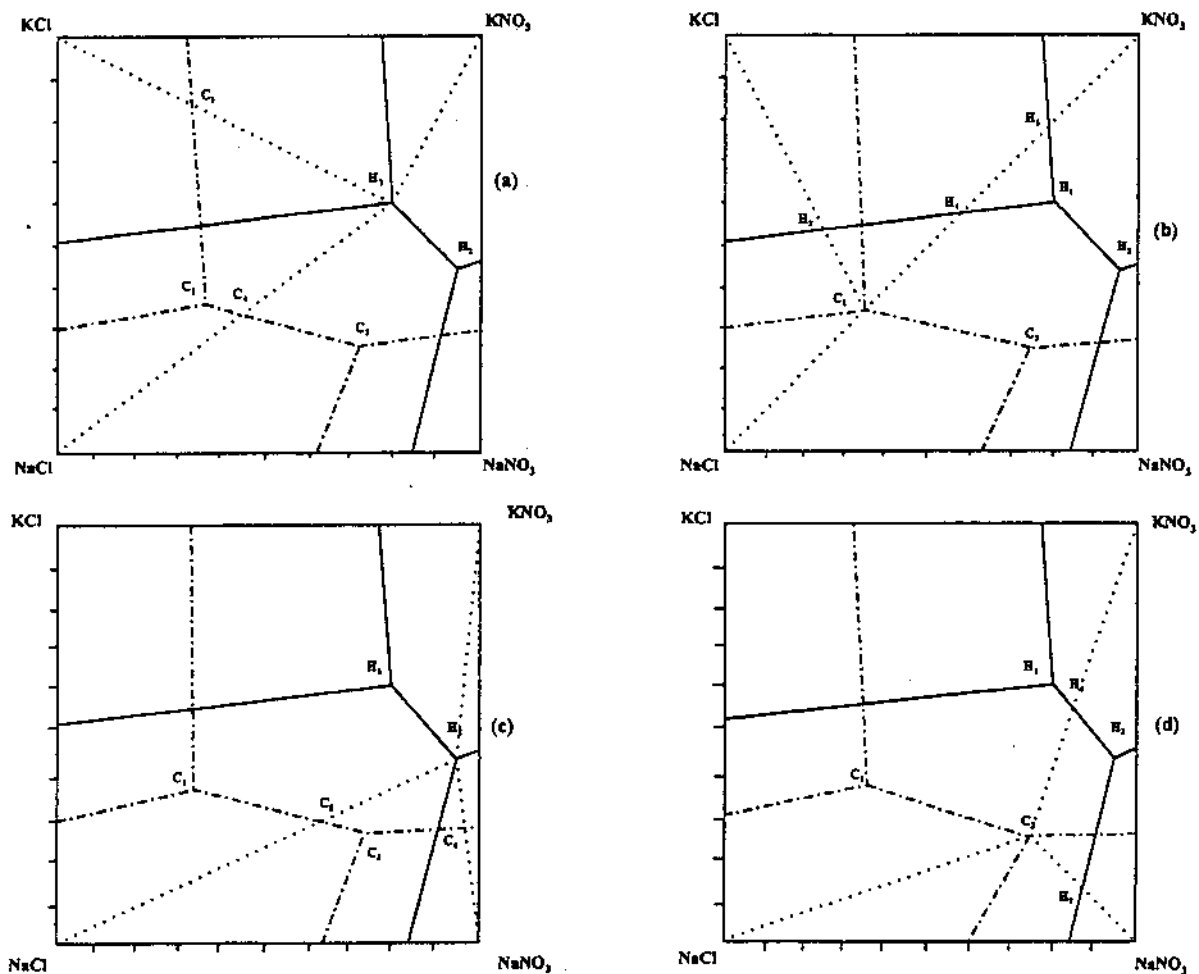

Figure 5. Identification of double saturation points that could be operating points.

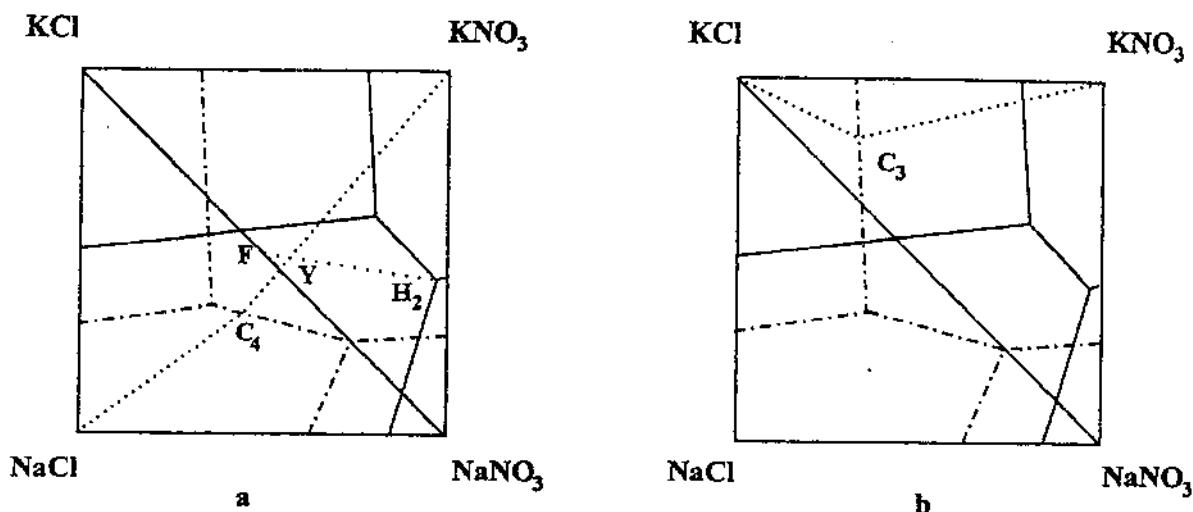

Figure 6. Verification of operational feasibility for points C_4 and C_3 .

solution (H_1) and the salts in equilibrium with the solution, it is possible to identify new potential operating points (C_3 and C_4). Also, it is possible to identify which salts can be precipitated at this point (KCl and NaCl) and those which cannot (KNO_3). Figures 5b, 5c, and 5d show the identification of other potential operating points (C_4 , C_5 , C_6 , H_3 , H_4 , H_5 , H_6 , H_7) based on the triple saturation points C_1 , H_2 , and C_2 .

Once the potential operating points are identified (C_3 , C_4 , C_5 , C_6 , H_3 , H_4 , H_5 , H_6 , H_7), it is necessary to determine if it is possible to reach these points by operating a crystallizer fed from other feeds and operating points. Figure 6a shows that C_4 is in equilibrium with NaCl and KNO_3 , and therefore could in principle produce either of these salts. However, C_4 cannot be used to produce NaCl, since there is no point or combination of points available to construct an intersection with the NaCl- C_4 line. Conversely, C_4 could be used to produce KNO_3 because there are several combinations of points that could form an intersection with the C_4 - KNO_3 line. At least one such feed mixing line must intersect the crystallizer mass-balance line in order to produce the stipulated pair of saturated solution-salt.

Figure 6a shows the feed combination (F)- H_2 as an example (feed combination F with H_2 can give point Y, if they are

mixed in adequate proportions). Figure 6b shows that point C_3 cannot produce any of the salts because there is no combination among the selected operating points and the KCl- C_3 or C_3 - KNO_3 lines. This not only eliminates C_3 as a possible operational point, but also eliminates the possibility of producing KCl using point H_1 . Other potential operating points could be double saturation points that are found on the diagonal of compatible salts. This is not considered in the present example, but will be analyzed below later.

The selection of operating points can be summarized as follows:

- (1) Select all the triple saturation points as potential operating points (such as C_1 , C_2 , H_1 , H_2).
- (2) Join each one of these points with its salts in equilibrium (tie lines). All double saturation points crossed by these lines are considered new potential operating points. Also include double saturation points that occur on the diagonal for compatible salts (such as C_4 , C_5 , C_6 , H_3 , H_4 , H_5 , H_6 , H_7). For a mathematical procedure to identify new potential operation points, see Appendix A.
- (3) For each potential operating point, analyze its potential existence by verifying if it is possible to cut the line connecting it with its salt in equilibrium by means of a linear combination of the other selected points. (Here it is necessary to

Table 1. Identification of Nodes and Arcs

Point	Solid Phase	Starting from									
		KCl	$NaNO_3$	C_1	C_2	C_4	C_5	H_1	H_2	H_4	H_6
C_1	KNO_3	x	x								
C_2	NaCl	x	x	x	x						
C_4	KNO_3	x	x	x		x	x	x	x	x	x
	NaCl	x	x	x							
C_5	KNO_3	x	x	x	x						
	NaCl	x	x	x		x	x	x	x	x	x
H_1	KNO_3	x	x	x	x	x					
	NaCl	x	x	x	x	x					
H_2	KNO_3	x	x	x	x	x	x	x	x	x	x
	NaCl	x	x	x	x	x	x	x	x	x	x
H_4	KNO_3	x	x	x	x	x	x	x	x	x	x
	NaCl	x	x	x	x	x	x	x	x	x	x
H_6	NaCl	x	x	x	x	x	x	x	x	x	

include other known points, such as feeds and double salts, such as $C_1, C_2, C_4, C_5, H_1, H_2, H_4, H_6$). For a mathematical procedure to verified feasibility, see Appendix B.

(4) Repeat step three until the potential operating points remain constant (such as $C_1, C_2, C_4, C_5, H_1, H_2, H_4, H_6$).

This *a priori* specification of the permissible operation points can be the main limitation of this technique. However, a more complex representation, as with a thermodynamic model, cannot be a good decision, because impurities can affect the operation condition. Also, it is important to understand that the true operating points will actually fall near, but not at, points selected as earlier, in order to avoid coprecipitation of salts and to have a level of supersaturation to allow crystallization. It is deemed unlikely that these small composition differences will affect the selection of the most viable alternative.

Construction of the flow network

Once the potential operating points have been selected, it is necessary to identify the interconnections that are feasible. This is done in a way similar to the identification of the operating points, that is, by joining each point to its solid phases. However, now attention is centered on identifying which solid phase can be produced, and from which other operating points.

Table 1 shows the identification of the solid phases that each point is able to produce in the preceding example, and the points of origin. As can be observed for some points such as C_2 , more than one salt can be produced. The flow network can be generated using this table, reading by columns. Thus, C_1 can produce KNO_3 starting from the combinations of feeds and points $C_2, C_4, C_5, H_1, H_2, H_4$, and H_6 . Figure 7 shows the flow network for the present example. This network is constructed as follows: first, nodes are included for each feed, including solvent for dissolution (nodes 1, 2, and 3). Then a node is included for each potential operating point (nodes 4 to 14). If a potential operating point could be used to produce more than one salt, a node must be included for each salt. Also, nodes must be included for intermediate products such as double salts. Finally, nodes must be included for each final product desired (nodes 15 to 17). Again, a node must be included for the solvent in order to account

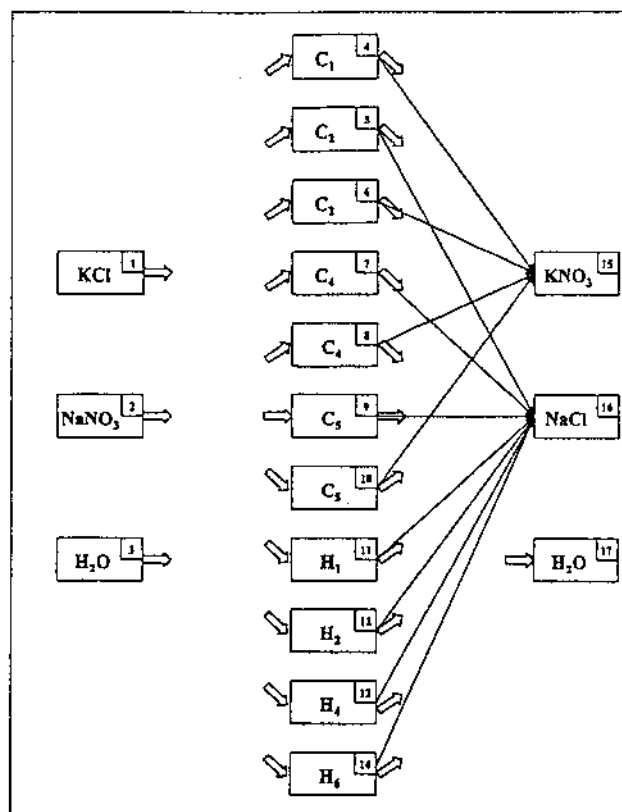

Figure 7. Flow network for KNO_3 production example.

for evaporation steps. The nodes have been numbered to clarify the following explanations.

The interconnections among the nodes (arcs) could be drawn in the diagram. Figure 7 includes only the arcs that represent salt production, with all the other interconnections implied in the diagram by the thicker arrows. A simpler way to identify all the arcs is to use an origin-destination matrix. Table 2 shows the interconnection matrix for the present example. All the nodes that can receive some type of flow are listed as the columns (destination nodes), while all the nodes that generate some type of flow (nodes of origin) are listed as

Table 2. Origin-Destination Matrix of the Arcs in the Flow Network

Nodes of Origin	Destination Nodes													
	4	5	6	7	8	9	10	11	12	13	14	15	16	17
	C_1	C_2	C_2	C_4	C_4	C_5	C_5	H_1	H_2	H_4	H_6	KNO_3	$NaCl$	H_2O
1	1	2	3	4	5	6	7	8	9	10	11			
2	12	13	14	15	16	17	18	19	20	21	22			
3	23	24	25	26	27	28	29	30	31	32	33			
4		34	35	36	37	38	39	40	41	42	43	44		132
5	45				46		47	48	49	50	51		52	133
6	53				54		55	56	57	58	59	60		134
7	61	62	63			64	65	66	67	68	69		70	135
8	71	72	73			74	75	76	77	78	79	80		136
9	81	82	83		84			85	86	87	88		89	137
10	90	91	92		93			94	95	96	97	98		138
11	99		100	101	102		103		104	105	106		107	139
12	108		109		110		111	112		113	144		115	140
13	116		117		118		119	120	121		122		123	141
14	124		125		126		127	128	129	130			131	142

rows. Obviously, some nodes function simultaneously as both origins and destinations. The arcs within the matrix are numbered. Tables 1 and 2 delineate the possible connections between the nodes for consideration by the LP solver.

Mathematical formulation

The mathematical formulation is similar to that of Cisternas (1999). It is first necessary to define a set that includes all the nodes of the system

$$S = \{s; \text{all nodes in the system}\}$$

This includes feeds, products, multiple saturation points (double and triple), and solid intermediate products such as double salts. All the components including ions and solvent will be denoted by the set $I = \{i\}$. The arcs, which denote flows between the nodes, will be represented by the set $L = \{l\}$.

To establish the mathematical model, it is necessary also to define the following subsets:

$S_M = \{s | s \in S, \text{ multiple saturation point and intermediate products nodes}\}$

$S_F = \{s | s \in S, \text{ feed nodes with flow rates of species } i \in I \text{ specified}\}$

$S_P = \{s | s \in S, \text{ product nodes with flow rates of species } i \in I \text{ specified}\}$

$S^{in}(s) = \{l | l \in L, \text{ is an inlet to node } s, s \in S_M\}$

$S^{out}(s) = \{l | l \in L, \text{ is an outlet from node } s, s \in S_M\}$

$F(s) = \{l | l \in L, \text{ is an outlet from node } s, s \in S_F\}$

$P(s) = \{l | l \in L, \text{ is an inlet to node } s, s \in S_P\}$

$I_p(s) = \{i | i \in I, \text{ is a component specified in node } s, s \in S_P\}$

$I_f(s) = \{i | i \in I, \text{ is a component specified in node } s, s \in S_F\}$

Each flow l has an associated variable that represents the molar flow w_l , and an associated parameter $x_{l,i}$, which represents the molar composition of component i in the flow l .

The constraints applicable to the separation problem are defined by the material balances and the feeds and product specifications. The equilibrium conditions are implicit in the material balances, given that the compositions of the flows have been specified. The constraints are as follows.

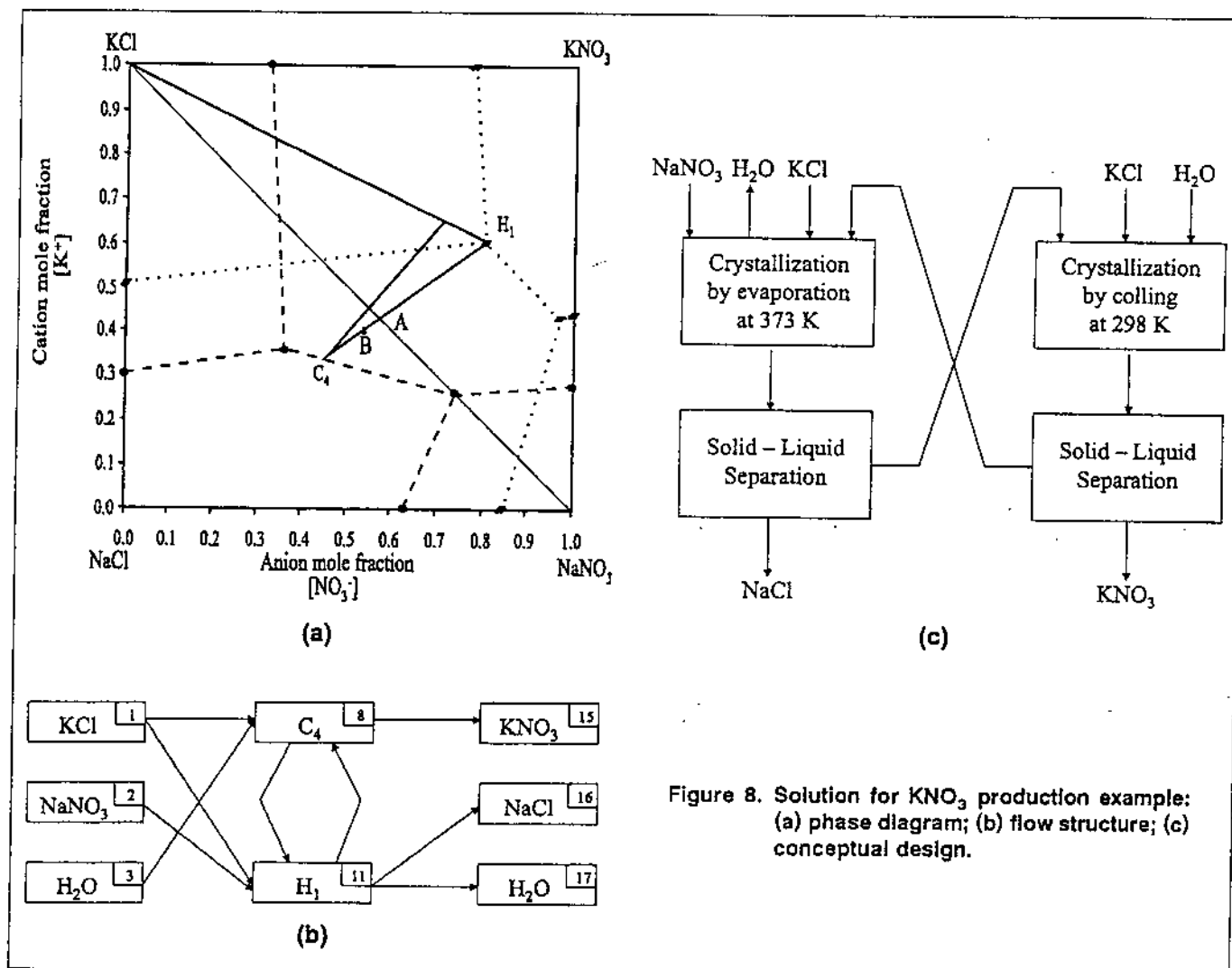

Figure 8. Solution for KNO₃ production example: (a) phase diagram; (b) flow structure; (c) conceptual design.

- Mass balance over operating point nodes for each component

$$\sum_{l \in S^{in}(s)} w_l \cdot x_{l,i} - \sum_{l \in S^{out}(s)} w_l \cdot x_{l,i} = 0 \quad s \in S_M, \quad i \in I \quad (1)$$

- Specification of feeds flow rates

$$\sum_{l \in F(s)} w_l \cdot x_{l,i} = C_{s,i}^F \quad s \in S_P, \quad i \in I_F(s) \quad (2)$$

where $C_{s,i}^F$ is the desired flow rate of component i in feed s .

- Specification of product flow rates

$$\sum_{l \in P(s)} w_l \cdot x_{l,i} = C_{s,i}^P \quad s \in S_P, \quad i \in I_P(s) \quad (3)$$

where $C_{s,i}^P$ is the desired quantity of component i in the final product s .

The objective function consists of minimizing total annualized costs. However, in the present study minimization of the sum total of all mass flows will be considered as the approximate objective function, that is

$$\min \sum_{l \in L} MW_l w_l \quad (4)$$

where MW_l are the molecular weights of each flow. In order for the objective function to adequately represent the total cost, the energy inputs and equipment specifications must be included. It is not possible to assign a cost directly to each node or flow, given that the same equilibrium operating point might include a crystallization by evaporation, a crystallization by cooling, a chemical decomposition, or a leaching. In order to maintain the simplicity of the model, energy inputs and equipment selection have not been included. In our experience in the development of these models, in many applications the inclusion of these two factors does not significantly affect the solution obtained by the model. If desired, these factors can be included by adding superstructures for energy integration and equipment selection as described by

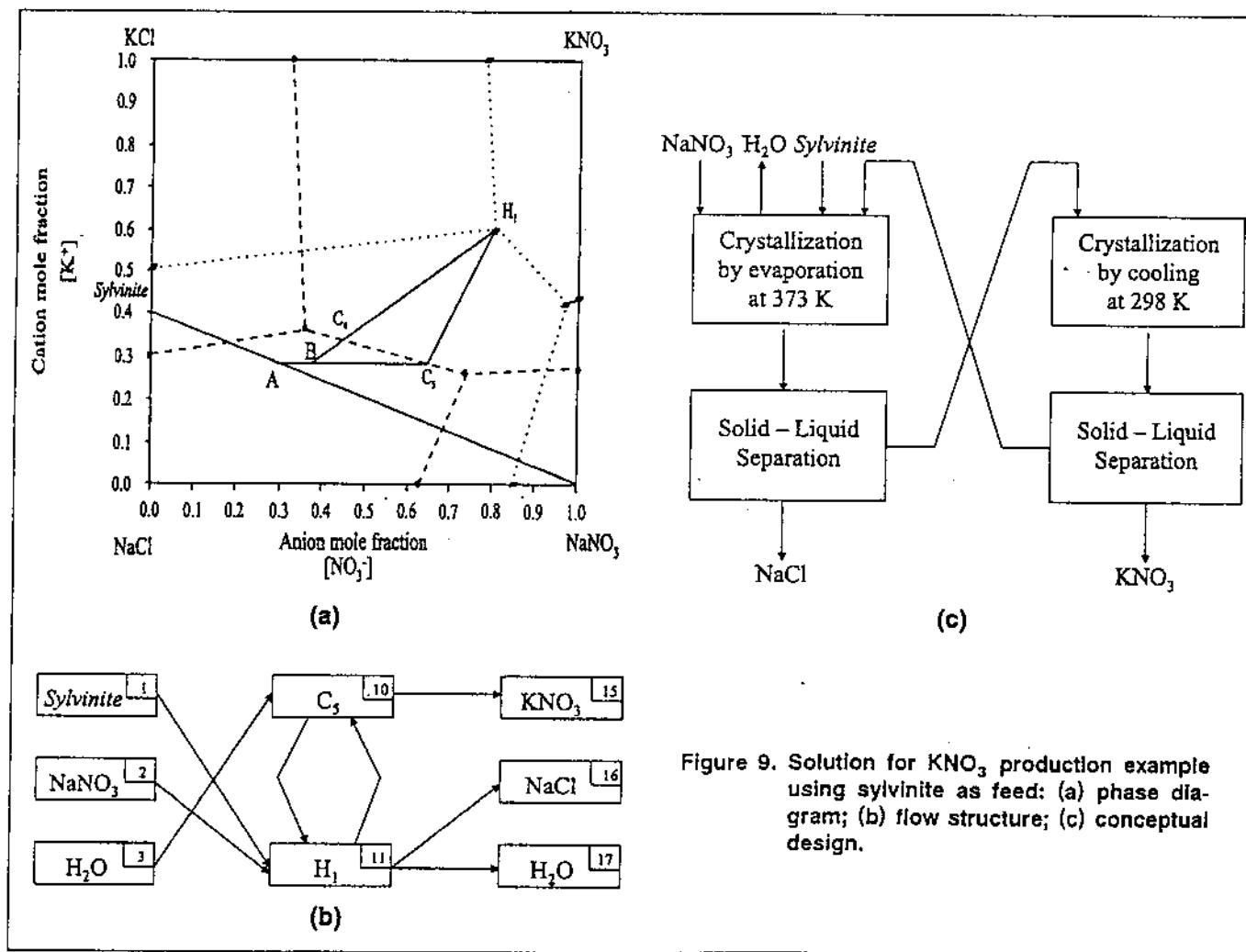

Figure 9. Solution for KNO₃ production example using sylvinit as feed: (a) phase diagram; (b) flow structure; (c) conceptual design.

Cisternas et al. (2001), which are completely compatible with the solution method of the present study.

Equations 1 to 4 represent a linear programming problem, which can be solved using standard algorithms.

Solution

The solution obtained for the preceding example is $w_5 = 25$, $w_8 = 75$, $w_{19} = 100.0$, $w_{27} = 96.3$, $w_{76} = 373.1$, $w_{80} = 100.0$, $w_{102} = 351.8$, $w_{107} = 100.0$, $w_{139} = 96.3$, and is depicted in Figure 8. A mixture rich in NaNO_3 (point A) is mixed with solution C_4 , which is then heated to 373 K, and evaporating part of the solvent permits separation of the NaCl . The remaining solution H_1 is mixed with the remaining KCl and is then cooled, with its solvent adjusted in order to obtain crystallization of KNO_3 . Once the crystals are separated, the solution is recycled to the mixer. Figure 8a is the process represented on

the phase diagram, Figure 8b is the flow structure, and Figure 8c shows the conceptual design. The industrial process generally operates at points C_5 and H_1 , and in comparison handles a mass flow that is about 2.6% greater than this solution.

Examples

Production of potassium nitrate from sylvinite and potassium and sodium nitrate

Two new situations are studied in this example. The first includes the possibility of using sylvinite (a mixture of KCl and NaCl) with sodium nitrate as feeds. The sylvinite considered in this example has a molar composition of 20% K^+ , 30% Na^+ , and 50% Cl^- . This example may be of interest because in some potassium nitrate plants the potassium chloride used has been obtained from sylvinite by flotation pro-

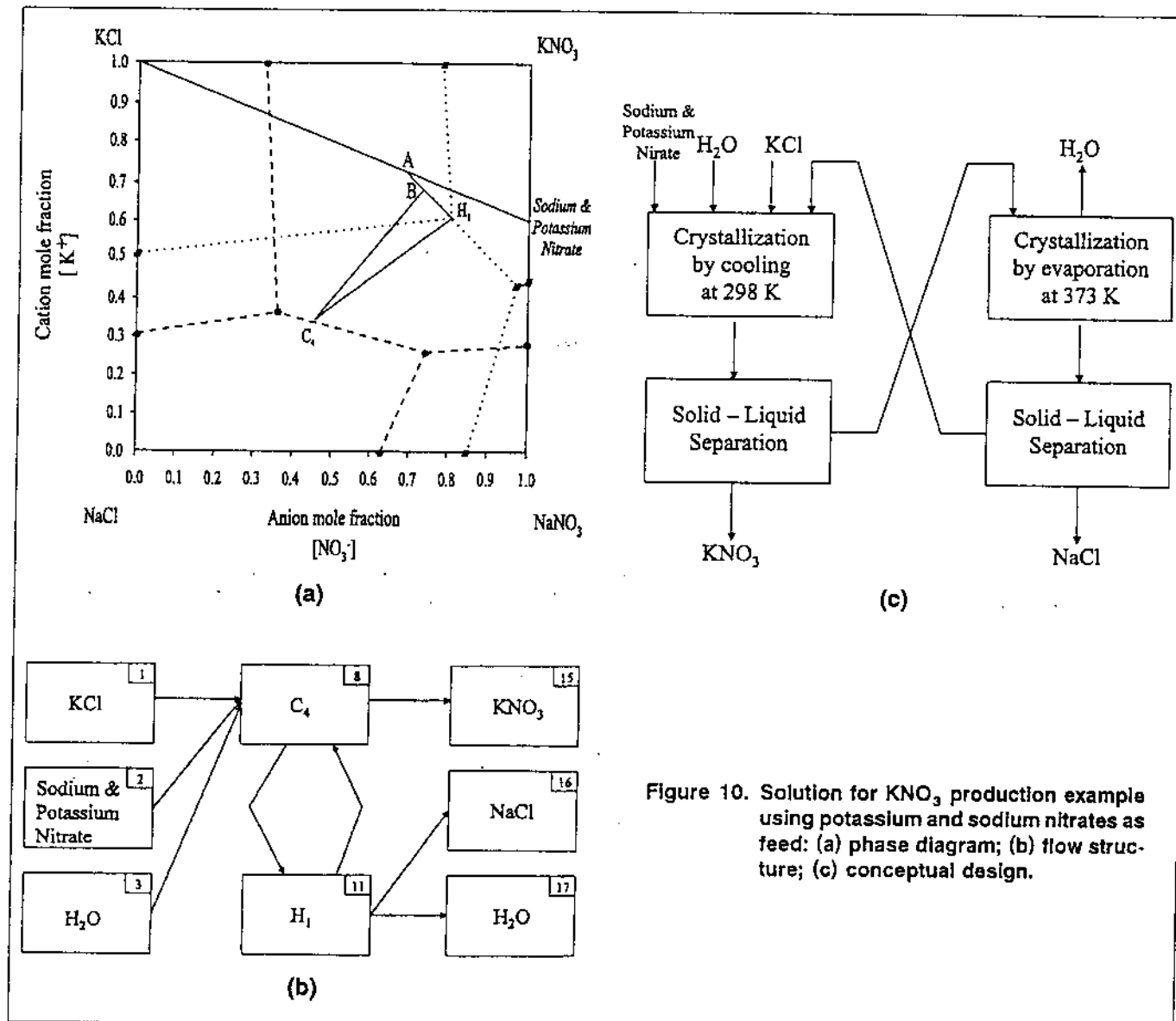

Figure 10. Solution for KNO_3 production example using potassium and sodium nitrates as feed: (a) phase diagram; (b) flow structure; (c) conceptual design.

cesses. Therefore, the possibility for the direct use of sylvinites will be analyzed.

Figure 9 shows the solution obtained for this problem. The sylvinites is mixed with NaNO_3 (point A in Figure 9a) and the C_5 solution to give the mixture at point B. This latter mixture is evaporated at 373 K to crystallize the NaCl . The remaining solution, H_1 , is recycled to the process. Figures 9b and 9c give the flow structure and conceptual design of the process.

A second example considers using potassium and sodium nitrates as feed instead of pure sodium nitrate. The nitrate mixture has a molar composition of 20% Na^+ , 30% K^+ , and 50% NO_3^- . To solve this problem, a procedure similar to that of the preceding problem is applied, and Figure 10 presents the solution obtained. The process uses the same points as the initial problem, but now KNO_3 is crystallized first instead of NaCl . The potassium and sodium nitrates are mixed with KCl (point A, Figure 10a) and a solution equivalent to that at point H_1 in order to produce the mixture at point B. The latter, once cooled, permits crystallization of KNO_3 . The resultant solution C_4 is submitted to evaporation and heating to 373 K in order to permit crystallization of NaCl and production of solution H_1 . Figures 10b and 10c show the flow structure and conceptual design, respectively.

Production of KClO_4 from KNO_3 and NaClO_4

This example considers the production of KClO_4 starting with KNO_3 and NaClO_4 . Figure 11 shows the Jänecke phase diagram for the system. The data were obtained from Linke and Seidell (1965). The triple saturation points are at H_1 , H_2 , C_1 , and C_2 . It can be seen that the crystallization field for KClO_4 is broad at 373 K and 298 K. It is also seen that the KClO_4 and NaNO_3 salts are compatible.

The operating point selection procedure allows us to identify points H_1 to H_5 and C_1 to C_7 . Points H_5 and C_6 were included because they were on the diagonal of the compati-

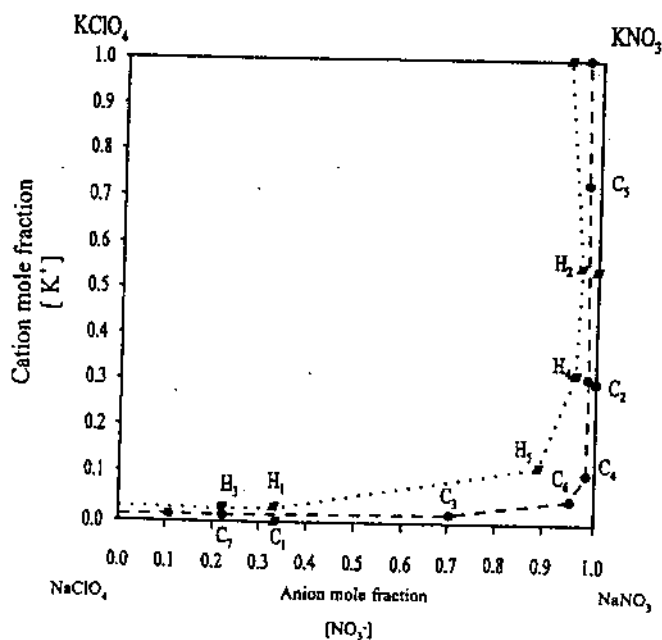

Figure 11. Phase diagram for the $\text{K-Na-NO}_3\text{-ClO}_4\text{-H}_2\text{O}$ system at 298 K and 373 K.

ble salts. As discussed by Berry and Ng (1996), it is possible to separate those salts using these points. An equimolar mixture of the raw materials can be mixed with a solution represented by point H_5 . By subsequent cooling and adjustment of the solvent, KClO_4 and a solution equivalent to C_6 can be produced. By heating solution C_6 and adjusting the solvent, NaNO_3 can be precipitated, obtaining solution H_5 , which is recycled. The advantage of operating on the diagonal is that it does not require recycling NaClO_4 or KNO_3 in the solutions. The flow superstructure is shown in Figure 12. There are 21 nodes, 15 of which represent double or triple saturation points. There are a total of 263 arcs (flows) between the nodes.

The solution for the problem is shown in Figures 13a, 13b, and 13c. The NaClO_4 is mixed with the 85.3% of the total flow of KNO_3 (point A) and solution H_2 to give point B. Once the solution is diluted and cooled, crystallized KClO_4 and solution C_4 are obtained. The latter solution is mixed with the remaining KNO_3 and heated to obtain crystallized NaNO_3 by evaporation. The summation of all the mass flows for this process is 58,861 for the production of 100 mol of KClO_4 . This solution to the problem compares with a sum of all mass flows of 72,829 for the process operating on the diagonal. This is explained by the fact that operation on the diagonal (points H_5 and C_6) requires recycling of larger amounts of solvent, a condition that cannot be observed in the Jänecke projection.

Conclusions

A procedure has been presented for the synthesis of processes for the separation of salts by fractional crystallization in systems formed by a pair of reciprocal salts. The method is

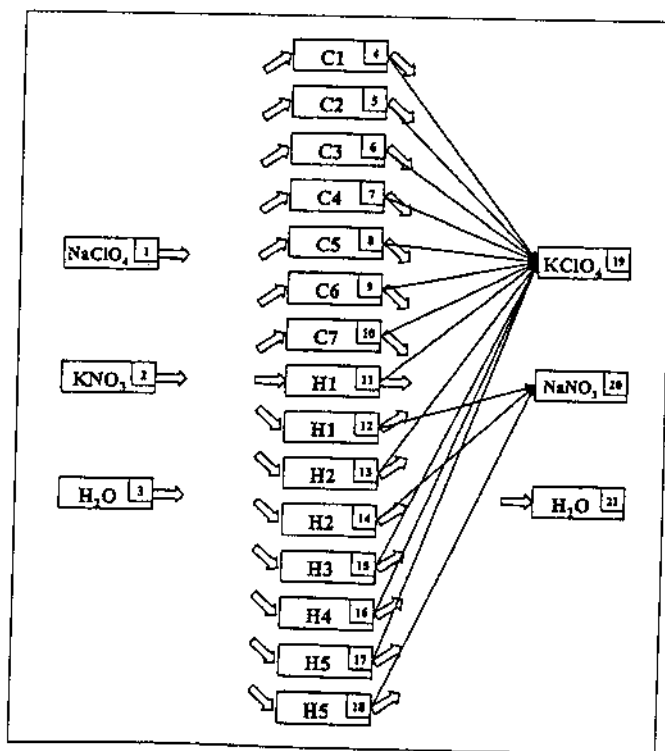

Figure 12. Flow network for KClO_4 production example.

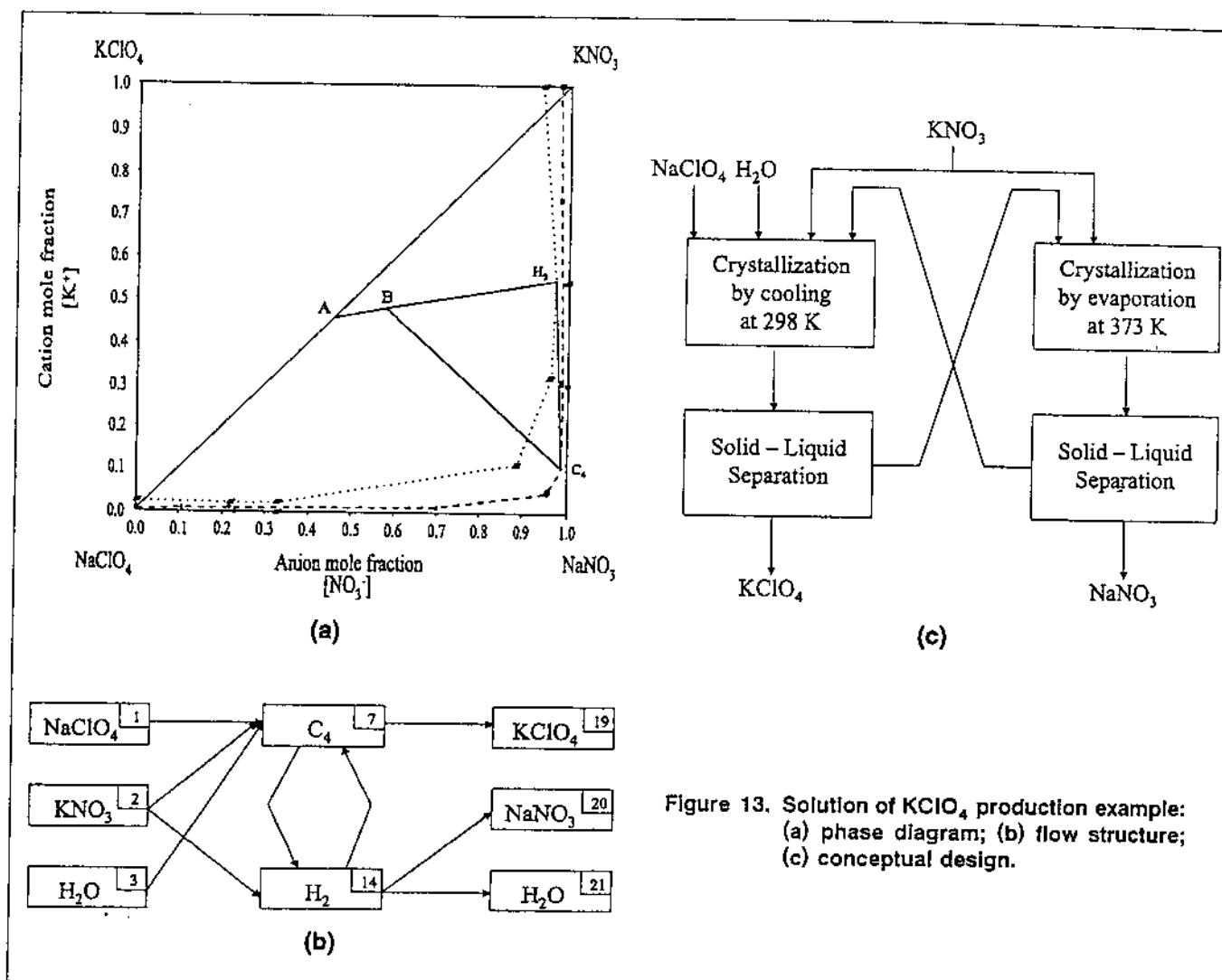

Figure 13. Solution of $KClO_4$ production example: (a) phase diagram; (b) flow structure; (c) conceptual design.

based on a description in terms of a network flow model, where the nodes represent thermodynamic states and the arcs represent flows between these states. The advantages of the method lie in its capability to consider general process flow pattern, handle systems forming double salt, deal with several temperatures as potential operation conditions, and handle several feeds and products. Also, since the model constraints are linear and since only a small number of nodes are necessary, the network optimization problem can be straightforwardly solved with standard algorithms.

The solution to the network flow problem indicates the underlying mass flow of the desired flowsheet. However, the method can be combined with superstructures for energy integration and equipment selection, as described by Cisternas et al. (2001), to search for minimum total cost. In this case the mathematical model became a MILP problem, which, given the small sizes implicated, standard algorithms should be quite sufficient.

The method has been applied to various examples that verify its utility in the search for conceptual designs for the processing of these systems.

Acknowledgment

The authors are grateful for support from CONICYT through FONDECYT Project 1990956, which made this research possible.

Literature Cited

- Berry, D. A., and K. M. Ng, "Separation of Quaternary Conjugate Salt Systems by Fractional Crystallization," *AIChE J.*, 42, 2162 (1996).
- Cisternas, L. A., and D. F. Rudd, "Process Designs for Fractional Crystallization from Solution," *Ind. Eng. Chem. Res.*, 32, 1993 (1993).
- Cisternas, L. A., and R. E. Swaney, "Separation System Synthesis for Fractional Crystallization from Solution Using a Network Flow Model," *Ind. Eng. Chem. Res.*, 37, 2761 (1998).
- Cisternas, L. A., "Optimal Design of Crystallization-Based Separation Schemes," *AIChE J.*, 45, 1477 (1999).
- Cisternas, L. A., C. P. Guerrero, and R. E. Swaney, "Separation System Synthesis of Fractional Crystallization Processes with Heat Integration," *Comput. Chem. Eng.*, 25, 595 (2001).
- Dye, S. R., and K. M. Ng, "Fractional Crystallization: Design Alternatives and Tradeoffs," *AIChE J.*, 41, 2427 (1995).
- Dudczek, J., "Synthesis of Crystallization Processes. Ternary Systems with a Single Congruently Soluble Double Salt," *Ind. Chem. Process.*, 22, 397 (2001).

- Fitch, B., "How to Design Fractional Crystallization Processes," *Ind. Eng. Chem.*, **62**, 6 (1970).
- Linke, W. F., and A. Seidell, *Solubilities*, Vol. II, American Chemical Society, Washington, DC (1965).
- Ng, K. M., "Systematic Separation of a Multicomponent Mixture of Solids Based on Selective Crystallization and Dissolution," *Sep. Technol.*, **1**, 108 (1991).
- Purdon, F. F., and V. W. Slater, *Aqueous Solution and the Phase Diagram*, Arnold, London (1946).
- Thomsen, K., P. Rasmussen, and R. Gani, "Simulation and Optimization of Fractional Crystallization Processes," *Chem. Eng. Sci.*, **53**, 1551 (1998).

Appendix A: Identification of New Potential Operation Points.

Let us consider that the reciprocal salt pair system has $j = 1, 2, 3, \dots, J$ solid phases and $i = 1, 2, \dots, I$ triple and double saturation points at one specified temperature and pressure. The number of triple points (tp) is $tp = J - 2$. The number of double saturation lines (dl) (connections between double saturation points-triple saturation points, and triple saturation-triple saturation points) are $dl = 2tp + 1$.

To identify which points are connected, let us define a_{ij} , where $a_{ij} = 1$ if point i is saturated with solid phase j , and $a_{ij} = 0$ if not. Then point i is connected with point k if $\sum_j a_{ij} a_{kj} = 2$. Each line connection, i, k , can be represented by two straight lines between points (z^i, r_c^i, r_a^i) and (z^k, r_c^k, r_a^k) , as $z = \alpha_z + \beta_z r_a$, and $r_a = \alpha_r + \beta_r r_c$, with $\min(r_a^i, r_a^k) < r_a < \max(r_a^i, r_a^k)$, where, z, r_c, r_a are the mol of water/equivalent, cation equivalent fraction, and anion equivalent fraction, respectively. The values of α, β can be easily determined from points i and k .

Each tie line between a solid phase j and a saturation point i can be represented by a line between points (z^i, r_c^i, r_a^i) , and

(z^j, r_c^j, r_a^j) , as $z = \theta_z + \psi_z r_a$ and $r_a = \theta_r + \psi_r r_c$, with $\min(r_a^i, r_a^j) < r_a < \max(r_a^i, r_a^j)$. The values of θ, ψ can be easily determined from points i and j .

The tie line i, j intercepts the double saturation line i, k in the point $r_a = (\alpha_r - \theta_r) / (\psi_r - \beta_r)$, where i is a triple point, if $\max(\min(r_a^j, r_a^k), \min(r_a^i, r_a^k)) < r_a < \min(\max(r_a^i, r_a^k), \max(r_a^i, r_a^k))$.

This intercept can be considered as a new potential operation point.

Appendix B: Verification of Feasibility of a Potential Operation Point

A potential operation point l , (z^l, r_c^l, r_a^l) , can be considered as an operation point to produce salt j , (z^j, r_c^j, r_a^j) , if it is possible to cut the line connecting it with its salt j by means of a linear combination of the other selected points p , (z^p, r_c^p, r_a^p) . This is

$$\beta r_c^l + (1 - \beta) r_c^j = \sum_p \alpha_p r_c^p$$

$$\beta r_a^l + (1 - \beta) r_a^j = \sum_p \alpha_p r_a^p$$

$$\beta z^l + (1 - \beta) z^j = \sum_p \alpha_p z^p$$

$$\sum_p \alpha_p = 1$$

$$0 \leq \beta \leq 1; \quad 0 \leq \alpha_p \leq 1.$$

Manuscript received Mar. 25, 2002, and revision received Jan. 2, 2003.